

ANCILE: DISMOUNTED SOLDIER TRACKING AND STRIKE WARNING

Fernando Maymí
United States Military Academy
West Point, NY 10996

Paul Manz
Project Manager Battle Command
Fort Monmouth, NJ 07703

ABSTRACT

Ancile is a prototypical information system that warns dismounted soldiers of incoming indirect fire attacks while reporting their location to existing command and control systems. The main component of this system is a pager-like device worn by the individual soldier. This device periodically transmits the location of the soldier and listens for threat warnings. When a threat warning is received, the pager sounds an audible or vibratory alarm that increases in frequency as the threat approaches. Depending on the type of ammunition and its trajectory, soldiers may have a few seconds to well over a minute to improve their protective posture before enemy rounds detonate near them. This paper details the requirements that are satisfied by Ancile and provides an overview of the system's architecture. It also discusses in detail the implementation of a working prototype and discusses the results of field testing that was conducted both by the researchers at the United States Military Academy and by external agencies during a live-fire exercise. We conclude by discussing other potential applications of this system and the work that remains to be done.

1. INTRODUCTION

One of the salient features of the United States armed forces today is the ability to leverage information technology to command and control forces around the world in real or near-real time. Advances in the technologies that integrate sensor and communications systems allow us, for instance, to know the precise location of every tank in the battlefield. One of the information systems that allows us to do this, and which has received significant attention from the media, is the Force XXI Battle Command Brigade and Below (FBCB2)/Blue Force Tracking (BFT) system (Robinson, 2003).

Every vehicle equipped with FBCB2/BFT is able to determine its location using global positioning system (GPS) technology, and then report that information to its higher headquarters using secure radio links. Vehicles equipped with FBCB2/BFT also receive a variety of messages from their higher headquarters, including the known locations of other friendly vehicles and the

suspected locations of enemy forces. FBCB2/BFT also allows units to send and receive threat warning messages that allow us to, for instance, alert friendly forces about incoming strikes.

Though FBCB2/BFT's strike warning messages are manually generated, there are other information systems in the U.S. Army's inventory that automatically generate threat warning messages without human intervention. One of these systems is the Lightweight Counter Mortar Radar (LCMR) (Gourley, 2002), which is able to detect projectiles in flight, compute predicted their predicted points of origin (POO) and predicted points of impact (POI), and automatically broadcast a warning message with this information. The entire process takes only seconds, which means the warning messages are sent while the projectiles are still in the air.

LCMR systems are currently deployed in a number of forward operating bases (FOBs) in Southwest Asia. These systems automatically generate threat warning messages that are relayed, through one of several possible command and control systems, to a warning system called the Wireless Audio Visual Emergency System (WAVES) (Avidan, 2005). The loudspeakers used by the WAVES system play a pre-recorded message to warn soldiers within the FOBs about the incoming rounds.

Though WAVES has been shown to be an effective warning system within the FOBs, it has two important shortcomings that are well addressed by Ancile. Firstly, WAVES requires the installation of loudspeakers within the FOBs, which effectively negates its use to alert soldiers who may come under fires while patrolling outside the base's perimeter. Secondly, WAVES can be used by our adversaries to determine the effectiveness of their unobserved indirect fires; even if they can't see the impact of the rounds, the loudspeakers reveal much information.

2. REQUIREMENTS

What is needed is a system that allows commanders to know the location of all their dismounted soldiers as well as warn those soldiers whenever a threat is inbound. Though the technologies involved in such a system are

not revolutionary, their novel combination and successful integration create challenges in balancing functionality, cost, and form. This is particularly evident when one considers the vast number of end systems that would be required to equip every dismounted soldier in a theater of operations. Specifically, the system must satisfy the following functional requirements.

The system must track the location of each equipped individual soldier and periodically report this information. Though the putative recipient of these location reports is FBCB2/BFT, it is possible that a number of other existing or future systems may eventually receive this information in addition to or instead of FBCB2/BFT. The use of a standard messaging format is therefore necessary.

The system must warn each equipped individual soldier each and every time that a projectile is predicted to impact within a given distance from the soldier's location. This distance parameter should be kept to a minimum to preclude false positives, but should account for the expected blast radius of the ammunition as well as for errors in determining the location and movement of the soldier and of the predicted POI.

The system must be reasonably secure. All communications should, of course, be encrypted, but the end system itself should not compromise friendly forces, even when captured intact by an opponent. This means that the information contained in the devices carried by individual soldiers should be minimal and of extremely limited utility to an adversary. Furthermore, the system should incorporate mechanisms that allow captured devices to be selectively excluded from participating in the network.

The system component that the individual soldiers will carry must be unobtrusive. The devices must be as small as possible and reminiscent of a commercial pager. They must also operate for extended periods of time, in the order of at least a week, in a tactical environment, with no required user interaction. The intent is that users will activate their devices, keep them on their person, and only notice them when an alarm is triggered. Though it is possible for the individual devices to provide some utility (e.g. GPS position or time) to the soldier, the user interface must be kept to an absolute minimum to preclude the device from becoming a distracter.

The system must be inexpensive. If we are to equip every soldier in a theater of operations with end devices, these must be inexpensive enough to permit mass fielding. The target cost for the components of the proof-of-concept prototype is less than \$500. This figure, though arbitrary, was considered a reasonable cost threshold by the research team and the project sponsor.

Many organizations use this dollar amount as the threshold at which items are considered expendable.

3. ALTERNATIVE ARCHITECTURES

The critical discriminator among the potential architectures that might be used to satisfy the above stated requirements is the location where the determination is made as to whether or not a soldier is inside a threat area. In other words, where will the system compare the location of an individual soldier with each known threat area to determine whether or not that soldier must be warned? This is the only computationally intensive calculation required to satisfy the requirements and is also the most critical aspect of the system; any error in this calculation will either erode trust in the system or result in injury or death, or both.

Since the discriminator is computationally intensive, the first architecture we considered centralized this operation in a number of fairly robust hosts that receive location reports from the individual soldiers and threat warnings from the sensor networks. These centralized hosts determine which soldiers are in a threat area and then transmit warning messages to those individuals. The advantage of this architecture is that it results in extremely simple (and thus inexpensive) end devices that communicate with a limited number of more complex and protected nodes. Among its disadvantages are potential data latency impacts and the lack of robustness caused by its reliance on the centralized nodes; if either the node or the communications route to that node is broken, a significant number of soldiers would lose the system's services.

In the end, we decided to push the computations out to the end devices. The main advantages of this distributed architecture is that the loss of a computational node (i.e. the end device) affects only the individual soldier as well as minimizing network delays. Though we use networking bridges to connect the end devices to command and control as well as to the sensor systems, the devices are not affiliated with a specific bridge. Instead, each device is able to exchange messages with any other system component, be it another end device or a bridge. The main disadvantages of our approach is the increased complexity and cost (still under \$500.) of the end pager-size devices that are to be carried by the soldiers as well as potential increased network loading. Additionally, care must be taken to ensure no unnecessary information is maintained in the end devices that might prove useful to an adversary.

4. PROOF-OF-CONCEPT PAGER

The prototype we built consists of two types of devices: an end device that is carried by the soldier, and a

bridge device that is mounted on a vehicle or at an operations center. The end device looks like a slightly oversized pager and runs on standard AAA batteries. The bridge we used was a specially configured laptop computer. Eventually, however, we envision the development of software and hardware for a bridge device that fits in a vehicular radio or FBCB2/BFT mount and has a form factor similar to the advanced systems improvement program (ASIP) single channel ground and airborne radio system (SINCGARS). The bridge also has a user interface that allows unit signal personnel to configure the system and manage encryption keys. Alternatively, the bridge device software could be hosted and/or integrated into an existing appropriate system such as FBCB2/BFT and eliminate the need for additional hardware in already-space-constrained tactical vehicles.

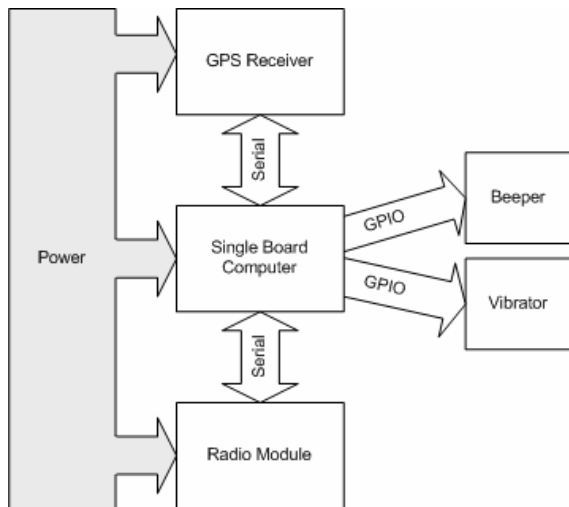

Figure 1: Ancile pager block diagram

Internally, both devices (the pager and the bridge) share most of the same components. The pager, as illustrated in the figure, consists of a computer, a radio module, a GPS receiver, and an audible alarm. The vibrating alarm, which is a requirement for any final version of this device, was not implemented in the prototype.

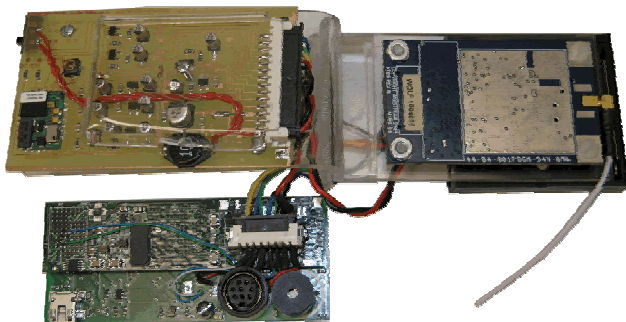

Figure 2: Open view of Ancile pager

The single board computer (SBC) is at the heart of the design. We chose the Gumstix Basix 400f, which is based

on the Intel XScale® PXA255 processor running at 400 MHz, with 64 MB of SDRAM, and 4 MB of Flash RAM. It also comes with the Linux 2.6 kernel, and has a very small form factor of 80mm x 20mm x 6.3mm. We chose this SBC because it provided a lot of computing power for a very reasonable price of under \$130. It also has four serial ports and plenty of general purpose input/output (GPIO) ports.

The GPS receiver in the prototype is the Motorola FS Oncore, which is very small, inexpensive, and capable of operating with very weak signal levels of around -142 dBm. Furthermore, the FS Oncore provides a host of advanced functionality including serial communications and the National Marine Electronics Association (NMEA) communications interface. This means that the SBC can communicate with the GPS receiver using text commands on a serial interface, which simplifies the software design. Support for advanced power management means that we can save power by putting the chip in sleep mode when not in use. The receiver is only 12mm x 16.6mm and costs less than \$40.

The radio module is the 9XTend™ wireless module by MaxStream. It is a 900 MHz frequency hopping, spread spectrum transceiver capable of transmitting at power levels between 1 milliwatt to one watt. The module also incorporates 256-bit Advanced Encryption Standard (AES) encryption and has a simple universal asynchronous receiver/transmitter (UART) interface that is controlled with standard AT commands. The 9XTend™ supports up to 65,000 network addresses on 10 independent networks, which enables us to support about a corps' worth of soldiers. Finally, the module is just 36.5mm x 60.3mm x 5mm and costs less than \$180.

All in all, the hardware components allowed us to build a working prototype measuring about 89mm x 44.5mm x 44.5mm (3.5in x 1.75in x 1.75 in). This form factor does not include the enclosure, which is needed for tactical use. We were able, however, to fit the pager prototype in a standard Government Issue first aid pouch. We also developed a somewhat hardened enclosure measuring 114.3mm x 57.2mm x 50.8mm (4.5in x 2.25in x 2in). Based on our preliminary research, we believe the productized version of the pager should be able to achieve at least a 33% reduction in size, which means the final rugged pager should still be able to fit in the first aid pouch as well as be clipped on a belt.

The bridge device was implemented using a laptop computer running the Linux operating system. This implementation decision was aimed at reducing the time required to produce a fully functional prototype system that could be tested. Though the final Ancile system bridge must support both eXtensible Markup Language (XML) messages over an Ethernet interface and Joint

Variable Format Message (JVMF) over a point-to-point protocol (PPP) interface, our prototype bridge only implemented the first. This first interface allows the system to interconnect with the warning (sensor) systems. The second interface (PPP) supports communications with FBCB2/BFT over SINCGARS and will be implemented in the future. As previously mentioned, the bridge device software could eventually be hosted and/or integrated onto another appropriate platform such as FBCB2/BFT or one of the numerous smaller ruggedized personal digital assistants (PDAs).

5. PROOF-OF-CONCEPT BRIDGE

We have developed two prototypes of the Ancile bridge device: one of basic functionality implemented on a Linux laptop computer, and another with advanced mapping and location reporting capabilities accessible through a graphical user interface. The first and basic bridge was developed in order to support the field testing of the pagers in early 2005. It was meant to be used by the development team only and thus required expert system knowledge to properly operate.

During early 2006, we ported the bridge device to the Microsoft Windows operating system and added a graphical user interface (GUI). This bridge prototype was intended to satisfy two important requirements that were not addressed by the previous one: graphically depict the location of the pagers on a topological map, and allow the user to insert arbitrary events by clicking on their desired locations. These are significant features that enable a non-technical user to fully employ the system.

This graphical bridge was built using Microsoft Visual Basic 6.0, a high level programming language. At the heart of this application is a collection of ArcObjects. ArcObjects are the building blocks of ArcGIS, geographic information system (GIS) software from ESRI. The bulk of the user interface is comprised of a MapControl Visual Basic control that embodies the necessary ArcObjects to provide interactive mapping functionality. Given map data and a geobase containing information about the entities to be displayed, the MapControl will depict these entities in their correct locations. Furthermore, the MapControl allows users to interact with the map data, allowing them to, for instance, easily view the coordinates of a point on the map by simply floating the mouse pointer over it.

Among the key features of this enhanced bridge application is the ability to list all the Ancile-equipped soldiers who are currently (or have recently been) reporting their locations. Whenever users select a soldier's unique identifier from the list, the application highlights that soldier's icon on the map, allowing users to quickly locate a specific soldier. Additionally, users

may select whether to show only the last known location for a soldier, or all previously reported locations. Figure 3 below shows the data for two soldiers: one who walked around the parade field at West Point but is no longer reporting his location, and another that is moving minimally around a spot on the west side of the field.

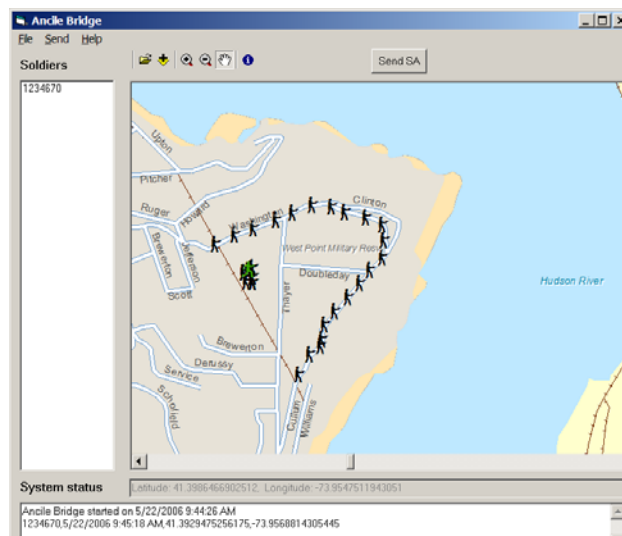

Figure 3: Ancile bridge showing soldier tracks

6. FIELD TESTING

Field testing was performed during a live mortar fire event at Yuma Proving Ground, Arizona in April of 2005. The basic premise of the test was that if the Ancile system was connected to the warning systems on a local area network (LAN), the pagers should generate alarms correctly. Since Ancile is designed to operate with no user intervention, the test was to be conducted likewise. All system inputs would have to come from the network interfaces. The only interaction with the system components was to be in setting them up for the test and in collecting data between trials.

The test plan did not involve the global positioning system (GPS) component of the Ancile pagers. Instead, the pagers were statically configured to use locations in the middle of the two impact areas: north and south. This limited scope was required by three key factors:

Hardware availability: with only three pagers on hand, the loss of any one could prevent the execution of the test plan. Had the pagers been placed in the impact areas, there was a significant probability that one or more would be destroyed by the mortar rounds.

Perceivable alarm range: The pagers have sound alarms intended to warn only the individual soldier. To extend the range at which the alarms could be perceived

would have required significant changes to the system architecture.

Status of development: The GPS component was not yet completely implemented. In fact, because of the preceding two factors, we decided to postpone GPS integration and concentrate on the other subsystems in preparation for the test.

In order to test Ancile, we connected the bridge device to a LAN on which a number of other hosts communicated. The bridge was then wirelessly connected to the two pagers that were used during the test. The diagram below depicts this setup, and includes the three systems of interest: Ancile, WAVES, AMDWS, and eTASS.

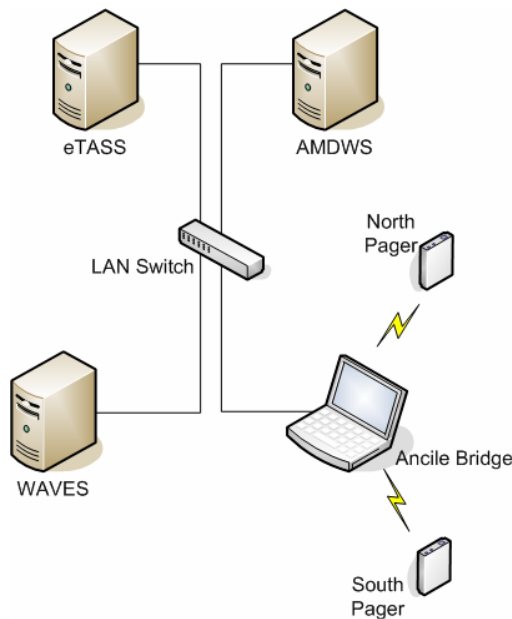

Figure 4: Ancile test topology

WAVES is an integrated alerting and site protection system based on a network of interconnected loudspeakers. It provides audible alerts triggered automatically (by messages, sensors or schedulers) or manually. The functionality of WAVES is similar to the warning functionality portion of Ancile, but the former is a fixed-site system with no portable components. WAVES can be externally triggered by XML messages that include the predicted point of impact as well as the radius of effects. These messages, in the test network, were being generated by the eTASS system.

The primary provider of warning messages in this LAN segment is the Air Missile Defense Work Station (AMDWS). AMDWS, in turn receives warning messages from the Forward Area Air Defense Command and Control (FAAD C2) system, which is directly connected to the sensors that detect the incoming fires. These

messages can be sent to any network host that is listening on the configured port. AMDWS messages use an XML schema that is different than that used by WAVES, but contains similar tags. Specifically, the latitude, longitude and altitude tags are identical.

eTASS is the Enhanced Tactical Automated Security System. This system is being developed by Northrop Grumman Mission Systems, but is not currently in the Army inventory. eTASS receives warning messages from AMDWS and generates XML messages in the WAVES format that can be transmitted to any network host that is listening for them. eTASS also provides the radius information that is absent for the AMDWS messages.

The Ancile bridge was connected to this network using an Ethernet adapter. The bridge was also equipped with a 900 MHz radio module which was connected to the laptop computer over a serial port. radio module was used to send and receive messages from the two pagers in the tests.

In a series of tests, the Ancile pagers were correctly stimulated by the sensor systems with no required changes to the later beyond providing them the internet protocol (IP) address of the Ancile bridge. In all cases but one, rounds launched at the northern impact area triggered the pager that was configured with static coordinates that placed it in that area. Similarly, rounds launched at the southern impact area triggered an alarm on the south pager. After detecting many mortar rounds, the only instance of a round not triggering an alarm occurred when pager erroneously calculated the POI as being 50 meters further away from the pager than it actually was. After examining the code, we found that a simplifying assumption in the algorithm that calculates the distance between the pager and the POI was to blame. We independently calculated the error introduced by this assumption as almost exactly 50 meters at the latitude and longitude of the test site.

7. FUTURE WORK

We are completing the integration of the GPS module so that the Ancile pagers are fully functional. This work should be completed by late summer of 2006. Once this is accomplished field tests will be performed to verify the position tracking functionality of the system. A significant item of interest in this process is the relationship between the range of the position report messages and the power cycle of the pagers.

Other improvements that should be incorporated this summer will improve the accuracy of the system time. When the pagers are not able to immediately acquire a GPS satellite signal, their internal clocks are very inaccurate. We propose to develop timing functionality

that will allow the system components (pagers and bridges) to slave their timing off of the most reliable time source available to them. This improvement will greatly enhance the reliability of test results as well as the overall functionality of the system.

Lastly, we are finalizing a licensing agreement which will allow a commercial entity to move the system out of our research laboratory and into materiel development and production realm. Being an academic institution, USMA is not resourced to produce much more than a small number of proof-of-concept prototypes. Every indication is that the system is viable and will greatly enhance the survivability of our dismounted forces. We just need the test data to prove this.

CONCLUSIONS

Ancile works. If we are able to maintain the unit price of the commercial pagers to \$500 or less, and we can maintain or improve the current size and power consumption of the devices, we should be able to equip every soldier in a combat brigade for between \$3 and \$5 million. This is comparable with the costs of equipping the same number of soldiers with Interceptor flak vests. Because only the bridge devices would require maintenance support, the additional sustainment requirements for the collective system would be relatively small.

The real power of Ancile becomes apparent when we consider that, for a minimal investment, we are able to place a computing platform with sophisticated communications and positioning capabilities in the hands of every soldier. This platform can later be exploited to provide a host of services for both the soldier and the commander. For instance, Ancile could very easily be modified to provide the following functionality:

- Improvised explosive device (IED) warnings could be generated with no changes required in the device. A secondary warning tone or pattern would allow the user to differentiate this threat from that of incoming rounds.
- Identification of friends and foes (IFF) with the addition of a muzzle-mounted direction sensor. This would also require adding software to keep track of the azimuth of incoming position reports from neighboring soldiers. The result would be an audible signal indicating the relative probability that the weapon is aimed at a friendly soldier.
- Automated generation of nuclear, biological and chemical (NBC) reports with the addition of NBC sensors.

- Squad-level communications with the addition of a headset.

Ancile addresses a critical need in today's ground forces. Our work has demonstrated the feasibility of this system. Every effort should be made to get this capability to soldiers in the field immediately so that further testing and maturation of the technology can be accomplished.

REFERENCES

- Avidan, A., "Warning, The Critical Element to Mitigate the Effects of a CBRN Attack" Proceedings of the 2005 National Defense Industry Association Conference, October 2005.
- Gourley, S.R., "Lightweight Counter-Mortar Radar" Army Magazine, April 2002.
- Manz, P.C., "System and Method for Tactical Centralized Event Warning/Notification for Individual Entities," U.S. Patent Application CECOM 5531, filed on 12 Jul 06, and corresponding Patent Cooperation Treaty filing on 31 Aug 06.
- Manz, P.C., "System and Method for Semi-Distributed Event Warning/Notification for Individual Entities," U.S. Patent Application CECOM 5530, filed on 12 Jul 06, and corresponding Patent Cooperation Treaty filing on 31 Aug 06.
- Manz, P.C. and Maymi, F.J., "System for Event Warning/Notification and Reporting for Individual Entities," U.S. Patent Application CECOM 5533, filed on 19 Jul 06, and corresponding Patent Cooperation Treaty filing on 31 Aug 06.
- Manz, P.C. and Maymi, F.J., "System and Method for Tactical Distributed Event Warning/Notification for Individual Entities," U.S. Patent Application CECOM 5532, filed on 19 Jul 06, and corresponding Patent Cooperation Treaty filing on 31 Aug 06.
- Maymí, F.J., Technical Report 051001-ANC-01: Dismounted Infantry Tracking and Strike Warning System; October 2005: Information Technology and Operations Center, West Point, NY.
- Maymí, F.J., Ancile Threat Warning Integration Test Report; May 2005: Information Technology and Operations Center, West Point, NY.
- Robinson, B.T., "Who Goes There?" IEEE Spectrum, October 2003.